



DIT-MCO TECHNICAL BULLETIN

5612 BRIGHTON TERRACE

KANSAS CITY, MISSOURI 64130

(816) 444-9700

FAX (816) 444-9737

8/1/97

JRS

2500.MBA—Multiple Bus Architecture

Introduction

Testing for opens and shorts in products containing relays create special problems. To completely test the interconnections you must use an external power supply to actuate the relays. Traditionally, to solve this problem you programmed an External Energization (EE) or a Latching Matrix (LM) to actuate the relays.

The past solution required splitting the interface cable from the tester to the product to connect the test point matrix and EE matrix. It resulted in interface cables dedicated to just one product. It also complicated future design changes that moved or added relays to the product, requiring new interface cabling. As the number of relays in the product increased, these problems multiplied.

DIT-MCO has a better method to completely test products that contain relays. The Multiple Bus Architecture (MBA) wiring analyzer has multiple test buses with *true* random access. The 2500.MBA is an efficient system for functional testing of relay panels, chassis and many other products that have special testing requirements. With the 2500.MBA you:

- Eliminate dedicated interface cables
- Get rid of split or “Y” connections
- Reduce interface cable inventory
- Easily adapt to product design changes
- Reduce test development time
- Save time and material

Multiple Bus Architecture

The Multiple Bus Architecture, as shown in Figure 1, provides power or instrumentation to any circuit connected to the system without needing special interface cables. The 1,000-point switching module contains the standard two system buses and two additional Random Access Switching System (RASS) buses that can connect to the required power or instrumentation. The system provides up to ten random access buses if needed. The additional buses are located in slave switching modules each containing up to four buses.

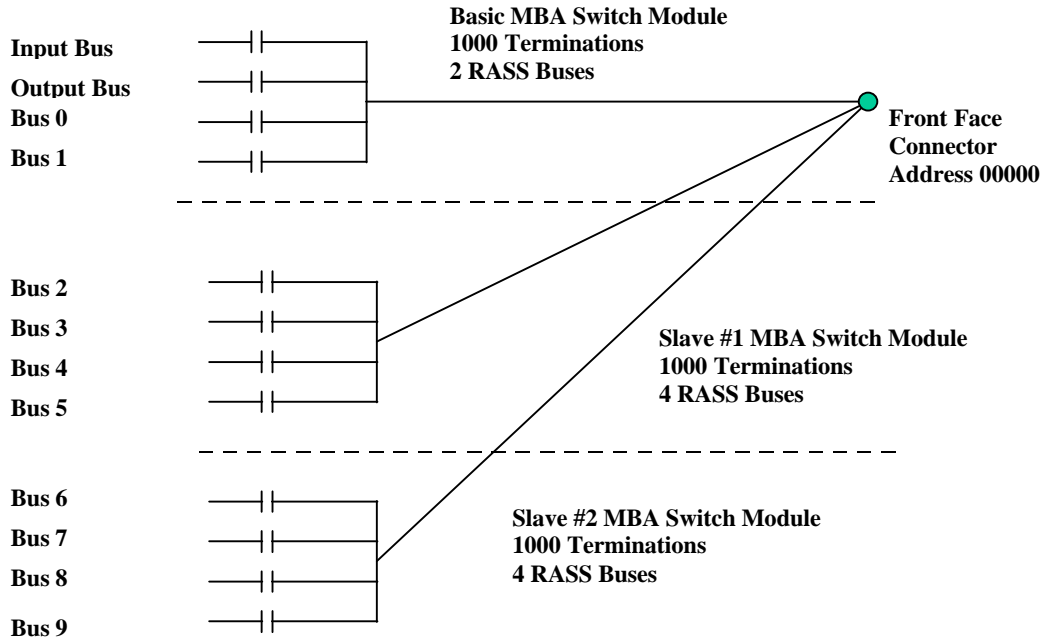

Figure 1. Typical front-face MBA test terminal with ten buses

The system buses connect to the internal DIT-MCO test instrument. The instrumentation uses the buses for output (+) and input (-) stimulus. You can assign any functionality to the random access buses (Bus 0–Bus 9).

An instrument and/or power supply routing switching matrix connects the power supply or instrument to the desired bus. The size of this routing matrix depends on the number of power supplies and/or instruments. Figure 2 shows a typical routing matrix connecting three power supplies to two buses.

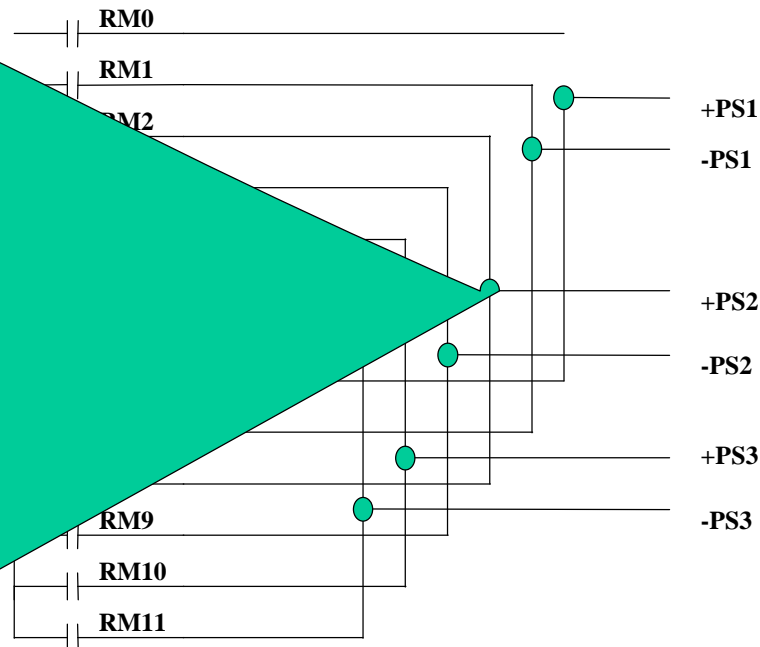

Figure 2. Typical bus to power connection—two buses to three power supplies

The random access relays are latching and mount on printed circuit boards. Each board contains 100 access points for two buses. The random access board attaches to a 100-point switching board via five connectors: one for control and four with test point access.

The random access relays can switch large currents with each relay rated for 2 amps. The printed circuit boards' design allows for short circuit currents up to 6 amps. The inputs to the buses are fused for 6 amps. When switching inductive and capacitive loads exercise care to prevent sticking of the switching contacts.

True Random Access

The expression "Random Access EE" has been loosely used to refer to the ability to apply power to any random test point. However, until DIT-MCO introduced the 2500.MBA, this has had its limitations. Previous designs only allowed a single switching board to connect to multiple buses so that a test point could also become a power point. This means that the remaining test points (perhaps up to 127) are no longer available for circuit testing when the board connects to a different bus. The end result is still special interface cables and does not solve the problem.

To illustrate this further, consider the typical relay circuit in Figure 3. It is impossible to test this simple circuit using the old design approach of connecting an entire switching board to a power bus. It still requires a special split cable to connect to one board with active test points and one board with relay power. However the 2500.MBA, with no special interface, easily tests this circuit using *true* random switching and random power capabilities.

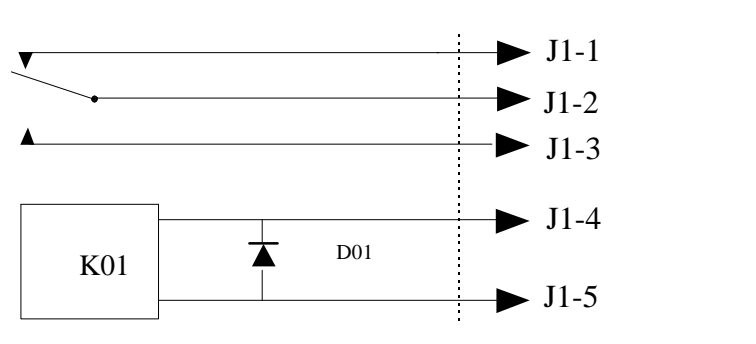

Figure 3. Relay circuit

System Configuration

Since most test applications for the 2500.MBA system are at the sub-assembly level such as a relay panel, they generally require less than 5,000 test points. Not all of these test points may need multiple buses. For example, a typical system might consist of 2,000 test points with only 1,000 points of multiple buses.

MBA Switching Module

A 1,000 point-MBA switching module contains up to ten 100-point switching boards, up to ten random access boards, and two control driver boards. The switching boards connect to the first two buses for use with standard instrumentation. These boards plug directly into the switching module motherboard. The second board provides the next two random buses. This board plugs directly to the first board through five connectors.

The switching's modular design makes it easily expandable. If more random access switching is needed in the future, it can be added in the field. Expand either at the module level in 1,000-point increments or at the board level with two buses of 100 points per board.

Each switching module has ten additional form "C" relay contacts for use and control by the test program. These extra latching relays provide additional buses when only a few buses are needed. Three contacts—the normally open, normally closed, and common—connect in whatever configuration is needed.

Standard MBA System Configuration

A 2,000 point system with 1,000 points wired for six buses is shown in Figure 4. This configuration fits into a double bay cabinet with overall height of approximately 5 feet (150 cm). This configuration contains a 115 VAC/400Hz power source, a programmable 0-36 VDC power supply, a fixed 28 VDC power supply, the switching controller and Single Board Comparator (SBC) assembly.

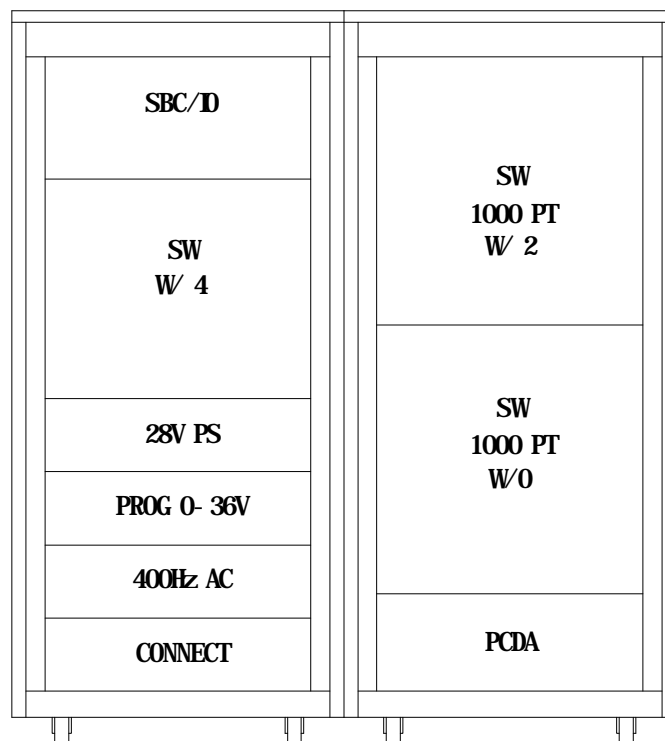

Figure 4. Typical configuration of a 2,000 test point system with six random access buses of 1,000 points each.

Portable MBA Configuration

A portable version of the MBA is shown in Figure 5. It contains 1,000 test points on four buses. The computer and monitor are mounted as part of the cabinet for portability.

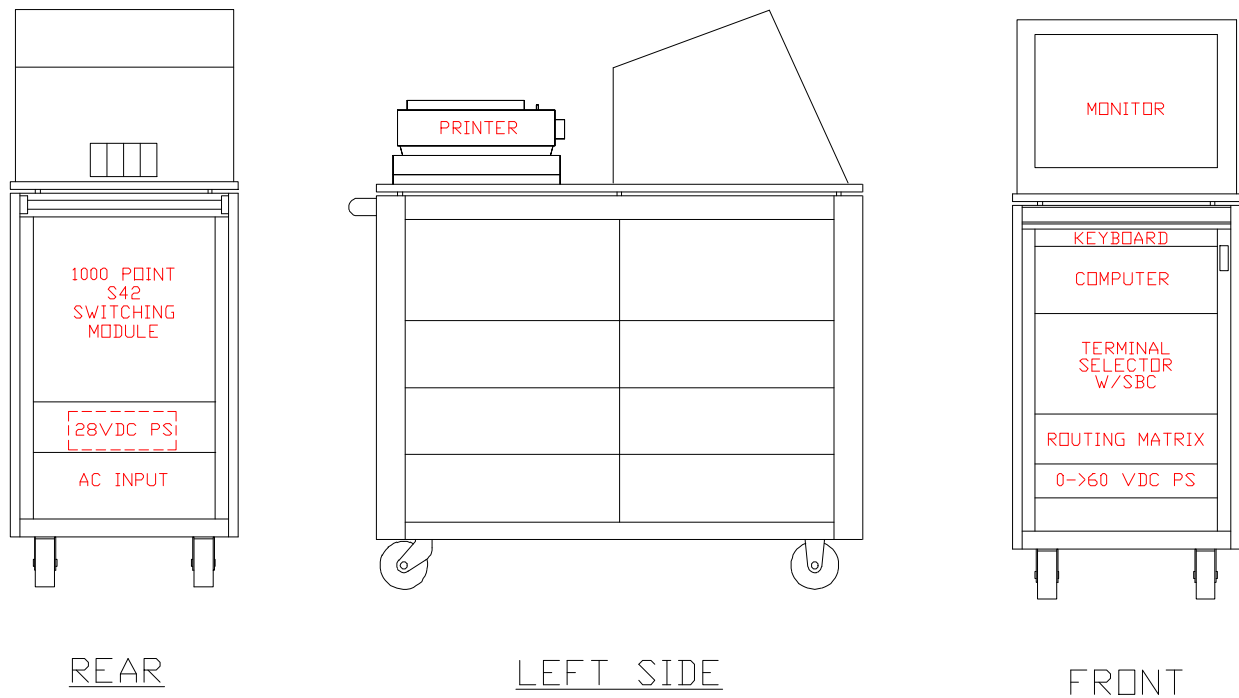

Figure 5. Portable 1,000-point, four-bus MBA analyzer

Switching Description

At the heart of the 2500.MBA is the new Series 42 switching. The random access bus portion of the switching uses “power” switching relays to apply power to the Unit Under Test (UUT). These relays latch and allow multiple buses to connect to a common test point. This enables using both power supplies and instrumentation to perform a test.

The basic MBA module has 1,000 points of Series 42 switching. The 1,000 points is made up of ten switching boards each containing 100 points of switching. A second board contains two, 100-point buses of latching relays for the random buses.

The random access relays actuate in any sequence necessary and are independent of the standard DIT-MCO input/output bus switching relays. This configuration allows the analyzer to perform standard continuity and insulation tests, and then where needed, apply power to the UUT.

The switching modules have two additional boards. The first has only the random access latching relays and is used in the slave switching module. It contains 100 points and two buses, plugging directly into a motherboard. The motherboard supports 20 of these boards for a total of 1,000 random access points on four buses. Internal cables to the master switching module connect each slave switching module.

The second type of board contains 100 test points of standard DIT-MCO input/output switching. This board is used in a switching module where only standard test point switching is needed. This board provides an economical solution to expanding the system without the additional cost and circuitry for the random access switching. This board cannot be upgraded to support the random access switching.

The 2500.MBA system expands with 1,000-point modules. These MBA modules can contain all random access switching or standard DIT-MCO input/output switching. This approach provides an economical solution to large systems with a mixture of random access switching.

A Routing Matrix (RM) connects the instrumentation and/or power supplies to the proper bus. The relays are latching and selectable under program control. The size of this routing matrix depends on the number of power supplies and/or instruments to be routed. The matrix is such that one of several power supplies or instruments can route to any of the buses.

MBA Programming Language

The MBA uses DIT-MCO's comprehensive Test Programming Language. It's the same software that operates the Series 2500, Series 2100, and other DIT-MCO test equipment. This test language accesses and controls the MBA. Commands specific to the MBA includes:

CONNECT,VARIABLE,ADDRESS	←Connects bus to specific address
DISCONNECT,VARIABLE,ADDRESS	←Disconnects bus from specific address
DISCONNECT,VARIABLE,ALL	←Disconnects all for any one bus
DISCONNECT,ALL	←Disconnects all power buses from the front face
RESET	←Disconnects all power buses and any other latched relays

where: **VARIABLE** is the unique variable that has been assigned to the power supply/instrument to a Random Access bus using the **ASSIGN** command. Note: the **VARIABLE** can also be a number from 0 through 9 corresponding to a Random Access bus.

ADDRESS is a test bus address (50 base) from 0 through 9949 for 5000 points of access.

ALL disconnects all points from the "BUS".

RESET disconnects all points from the all power buses and any other latched relays.

The Global Command **RESET** serves as a "Master Reset" to the MBA. It is recommended that this command immediately follows the last test command. **RESET** ensures unexpected connections and voltages are not present before the test process begins and leaves the system in a quiescent state after testing. This reset also clears any LM/EE commands and the RM.

The RM connects the power supplies to the proper bus in that portion of the Random Access Switching. Going back to Figure 2's matrix of two buses to three power supplies, here's the programming for it:

ASSIGN,VARIABLE,RM	←Assigns the VARIABLE to a RM relay contact
DEFINE,BUS,RM	←Defines the BUS to the RM relay contact

ROUTE,VARIABLE,BUS ←Connects power supply/instrument to specific bus
 REMOVE,VARIABLE,BUS ←Disconnects power supply/instrument from specific bus

where: **VARIABLE** is the unique variable assigned to the power supply/instrument to a Random Access bus using the **ASSIGN** command.

RM is the address of the routing matrix. It is a number from 0 through 99 corresponding to the relay assigned by the physical connection of the power supply/instrument to the routing matrix.

BUS is a number from 0 through 9 corresponding to a Random Access bus.

To ensure safe operation of the MBA switching with the UUT powered up, all “bulk” switching commands are inhibited. This prevents shorting out power supplies and damaging the UUT and/or switching relays. If needed, a programmer can override this feature with the mode directive BTO (Bulk Test Override).

Programming Example

This programming example shows a test to:

1. Ensure a relay’s coil is within the proper resistance range.
2. Detect a suppression diode.
3. Make certain the relay contacts are correctly wired when de-energized.
4. Energize the relay using the MBA feature.
5. Verify the relay contacts are correctly wired when energized.
6. Release the relay.

It assumes the relay is a 28 volt DC relay with a 500 (±10%) ohm coil. The suppression diode has a forward resistance of less than 200 ohms (equivalent) at 0.1 amp. The power supplies connect to the MBA buses using a routing matrix. The programming commands of this routing matrix are straightforward. The power supplies connect to the routing matrix in the order defined below by cables. In this example for a two-bus system, the power supplies and buses connect as defined in Figure 6. This allows connecting any power supply to any bus.

<u>RM #'s</u>	<u>Power Supply/Instrument</u>
0,6	+PWR_28 (Fixed 28V DC)
1,7	-PWR_28 (Fixed 28V DC)
2,8	+PWR_0-36 (Programmable 0-36 V DC)
3,9	-PWR_0-36 (Programmable 0-36 V DC)
4,10	P_115VAC (400 Hz.,1A,Single Phase) (Phase)
5,11	N_115VAC (400 Hz.,1A,Single Phase) (Neutral)

This adapted test circuit is as shown in the following figure:

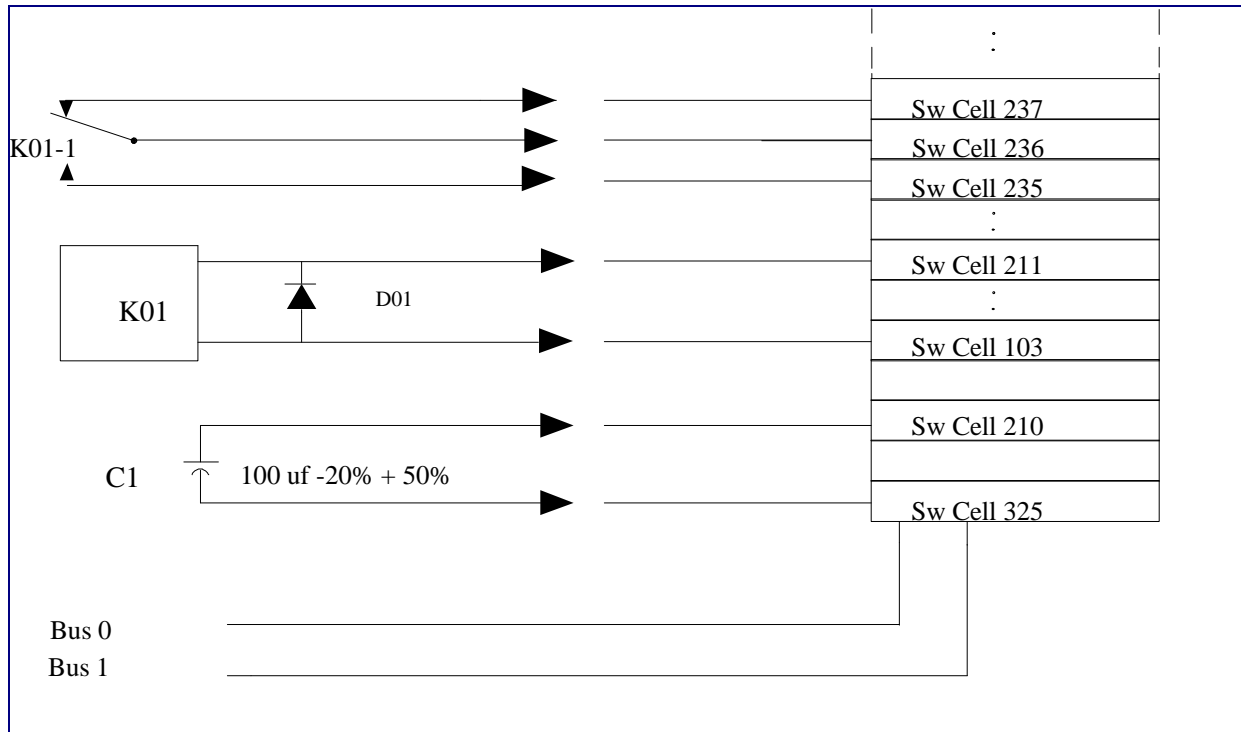

Figure 6. Adapted test circuit

The program starts with a reset of the MBA switching followed by parameters, test commands, MBA commands, more tests, more MBA commands and a reset. Note that the circuits are first tested for continuity and insulation before bus operations.

Example Test Program for MBA

```

RESET                                     ;Reset the entire switching system

ASSIGN,+PWR_28V,0                         ;Assigns the +terminal of the 28 Volt pwr supply to RM0
ASSIGN,+PWR_28V,6                         ;Assigns the + terminal of the 28 Volt pwr supply to RM6
ASSIGN,-PWR_28V,1                         ;Assigns the - terminal of the 28 Volt pwr supply to RM1
ASSIGN,-PWR_28V,7                         ;Assigns the - terminal of the 28 Volt pwr supply to RM7
ASSIGN,+PWR_0-36,2                        ;Assigns the + terminal of the 0-36 Volt pwr supply to RM2
ASSIGN,+PWR_0-36,8                        ;Assigns the + terminal of the 0-36 Volt pwr supply to RM8
ASSIGN,-PWR_0-36,3                        ;Assigns the - terminal of the 0-36 Volt pwr supply to RM3
ASSIGN,-PWR_0-36,9                        ;Assigns the - terminal of the 0-36 Volt pwr supply to RM9
ASSIGN, P_115VAC,4                        ;Assigns the P terminal of the115VAC Supply to RM4
ASSIGN, P_115VAC,10                       ;Assigns the P terminal of the115VAC Supply to RM10
ASSIGN, N_115VAC,5                        ;Assigns the N terminal of the115VAC Supply to RM5
ASSIGN, N_115VAC,11                      ;Assigns the N terminal of the115VAC Supply to RM11
DEFINE,0,0                                ;Defines Bus0 to RM0
DEFINE,0,1                                ;Defines Bus0 to RM1
DEFINE,0,2                                ;Defines Bus0 to RM2
DEFINE,0,3                                ;Defines Bus0 to RM3
DEFINE,0,4                                ;Defines Bus0 to RM4
DEFINE,0,5                                ;Defines Bus0 to RM5
DEFINE,1,6                                ;Defines Bus1 to RM6
DEFINE,1,7                                ;Defines Bus1 to RM7
DEFINE,1,8                                ;Defines Bus1 to RM8
DEFINE,1,9                                ;Defines Bus1 to RM9
DEFINE,1,10                               ;Defines Bus1 to RM10
DEFINE,1,11                               ;Defines Bus1 to RM11

```

```

F,500V,>100M,.005T,.01S ;Insulation Parameters
:
: ;Normal Testing
:
F103 ;Test bottom of coil for short
F235 ;Test lower contact for short
F236 ;Check common contact for short
C,1A,<5R,.05S ;Continuity Parameters for contact resistance
C237 ;Check NC for continuity
X211 ;Set Output for reverse diode
B,.01A,>500-10%,.025S ;Coil to be above 450 Ohms
B103 ;Check coil resistance and
E,.01A,<500+10%,.025S ;Coil to be below 550 Ohms
E103 ;To effect 10% tolerance tests
X103 ;Now setting up to check diode
G,.1A,<200R,.025S ;in forward direction.
G211 ;Must be less than 200 Ohms
ROUTE,+PWR_28V,1 ;Connects the +PWR1 28 V power supply to Bus1
ROUTE,-PWR_28V,0 ;Connects the -PWR1 28 V power supply to Bus0
CONNECT,-PWR_28V,103 ;Connect 103 to Bus1 to Operate Relay
CONNECT,+PWR_28V,211 ;Now connect cathode to +Power (Apply pwr to Relay K01)
DLY 1S ;Wait for relay to operate
X235 ;Set to N.O. Contact
C236 ;Check contacts did close
DISCONNECT,1,103 ;Disconnects 103 from Bus 0
DISCONNECT,2,211 ;Disconnects cathode from +Power
DLY 1s ;Wait again
X236 ;Set to Common Contact
C237 ;Check contacts did release
DISCONNECT,ALL ;Disconnects 103 from Bus0 and 211 from Bus1
REMOVE,+PWR_28V,1 ;Disconnects the +PWR1 28 V power supply from Bus1
REMOVE,-PWR_28V,0 ;Disconnects the -PWR1 28 V power supply from Bus0
: ;More Testing
:
A,CAP,>100µf,-30%,.2S ;Program Capacitance Comparator
X210 ;Setup output address
A325 ;Check that Filter Capacitor greater than 70 µf
RESET ;Reset All Latching Switching
END

```